



Investigation of the plastic drift capacity of RC frames with beam-column joint failure

C. Dong, J. Brunton & T.J. Sullivan

University of Canterbury, Christchurch.

ABSTRACT

MBIE/NZSEE guidelines have various methods to assess existing buildings, of which Displacement Based Assessment (DBA) is one. This paper reports on the application of DBA to reinforced concrete (RC) frames where beam-column joint shear failure governs. In the current guidelines, direct rotation method is recommended to estimate the probable drift capacity if plain round reinforcement is used. But the guidance is limited to beams, columns, and walls. This paper investigates the plastic drift capacity of RC frames possessing plain round bars and unreinforced exterior beam-column joints. A mechanics-based approach is proposed to estimate the plastic drift capacity of joints post-cracking. This approach suggests that the exterior beam-column joint can deform up to 1% after reaching shear strength without losing its gravity load bearing capacity. For verification purposes, the results of experimental tests are reviewed from the literature. The median plastic drift at a near-collapse limit state is found to be 1.3% with a dispersion of 0.8. Comparison has shown that the predicted plastic drift tends to be underestimated, and the uncertainties in the predictions require further research. Overall, the proposed joint mechanism provides an estimation of plastic drift capacity for RC frames that fail in joint shear. Experimental testing results suggest that the joint shear deformation values in the current C5 guidelines are overly conservative and that the newly proposed approach is more accurate and should be considered as part of future research.

1 INTRODUCTION

Poor seismic performance of many existing reinforced concrete (RC) buildings was observed during recent seismic events such as the 2010-2011 Canterbury earthquake sequence and the 2016 Kaikoura earthquake. This experience has highlighted the vulnerability of existing buildings to strong shaking, especially those that were designed pre-1970s. The New Zealand design standard prior to the mid-1960s did not have adequate guidelines on seismic structural detailing, which can result in unfavourable mechanisms and limited storey drift capacity (Fenwick & MacRae, 2009). To limit the risk of loss of life in future earthquakes, these existing buildings need to be assessed and strengthened as appropriate, using suitable seismic assessment

guidelines and procedures. In New Zealand, part C2 of the Seismic Assessment of Existing Buildings (MBIE/NZSEE, 2018) provides guidelines for various assessment methods of which, Displacement Based Assessment (DBA) is one such method. It assesses the strength and deformation capacity of a building, allows engineers to understand the interaction between different elements and the global behaviour. It also provides a check against the numerical models to help avoid cases where poor modelling assumptions are made.

This research focuses on RC frames that have deficient beam-column joints and usage of plain round reinforcing bars. Typical deficiencies include lack of transverse reinforcement and poor beam longitudinal bar anchorage (i.e., bent-in, bent-away, and hooked). Estimation of both the strength and deformation capacity of such joints is important in the seismic assessment of older buildings since the results can affect the expected sway mechanism, the total displacement capacity and the %NBS rating. In this paper, existing guidance for the assessment of beam-column joints is reviewed and a new method for the prediction of joint deformation capacity is proposed. Subsequently, results from previously conducted experimental testing campaigns are used to evaluate the accuracy of the guidelines.

2 ASSESSMENT OF THE STRENGTH AND DEFORMATION CAPACITY OF BEAM-COLUMN JOINTS

2.1 NZSEE/MBIE Guidelines

Part C2 of the guidelines recommend using the simple lateral mechanism analysis (SLaMA) as a first step of any seismic assessment. SLaMA can be considered as the reverse of the capacity design and requires knowledge of the probable strength of each element to identify a strength hierarchy, leading to identification of the corresponding weakest link. The strength hierarchy provides a basis to determine the global lateral strength and offers insight into the probable inelastic deformation mechanism. Relevant guidance specific to beam-column joints can be found in part C5 of the MBIE/NZSEE guidelines (2018) and Sullivan (2019).

To determine the strength hierarchy in RC frames, the guidelines recommend comparing the moment and shear strength of beams, columns, and the beam-column joint in terms of an equivalent column moment. A moment-curvature analysis can be used to compute the moment capacity of the beams and columns. The probable joint shear strength is computed in accordance with part C5 of the guidelines, as

$$V_{jh} = 0.85v_{jh}b_jh_c \leq 1.92\sqrt{f'_c} b_jh_c \quad (1)$$

where: v_{jh} is the probable horizontal joint shear stress; b_j is the effective width of the joint; and h_c is the column depth. The probable horizontal joint shear stress is the lesser of principal tension or compression stresses, $v_{jh,t}$ and $v_{jh,c}$ respectively, computed via Equations (2) and (3) for joints with no effective shear reinforcement.

$$v_{jh,t} = \sqrt{(k_j\sqrt{f'_c})^2 + k_j\sqrt{f'_c} \frac{N^*}{A_g}} \quad (2)$$

$$v_{jh,c} = \sqrt{(0.6f'_c)^2 - 0.6f'_c \frac{N^*}{A_g}} \quad (3)$$

where N^* is the axial load; and k_j is the coefficient for different types of bar anchorages.

Part C5 of the MBIE/NZSEE guidelines also provides guidance on estimating the probable deformation capacity of RC beams, columns, and walls. The guidelines recommend two approaches which are the moment-curvature method and the direct rotation method. For RC structures with plain longitudinal reinforcement, the direct rotation method is recommended by the guidelines. This method is derived based

on experimental data which implicitly accounts for many factors that can affect the deformation capacity, but it is limited to certain element configurations that were tested.

The guidelines do not appear to provide an expression for estimating the global deformation capacity of a RC frame. Priestley (1998) proposed a simple equation to predict the yield drift ratio of frames, which includes contributions from beam flexure and shear, column flexure and shear, and joint shear deformation. But Priestley (1998) also pointed out that this equation is not suitable for assessment of pre-1970's buildings, as inadequate seismic detailing is likely to be more flexible than predicted.

When assessing a RC frame, the behaviour of the beam-column joints should be understood properly, because it has been shown that joint failure may change the global failure mechanism. For example, Pampanin (2003) observed that the concentration of deformation in shear cracks developed in the joint panel zone delayed the formation of a soft-storey mechanism. Under certain conditions, shear deformation in a joint may reduce the rotation demand in the adjacent beams and columns, postponing the soft storey mechanism. However, the rapid strength degradation that can occur in joints could lead to loss of vertical load bearing capacity. Based on recent literature, NZSEE/MBIE guidelines recommend a limiting shear deformation of 0.001 (radians) for unreinforced exterior beam-column joints with plain bars at ULS. After reviewing test results in the literature, it will be argued that this value is overly conservative and joints can deform further without collapsing.

2.2 Plastic Deformation Capacity of Unreinforced Exterior Joints with Plain Bars

Considering there is little guidance on joint deformation capacity in the literature, it is worth considering how much a joint can deform before losing its gravity load bearing capacity. A simple mechanics-based approach is proposed to estimate the probable deformation capacity of such joints. It suggests when the joint shear strength is reached, a diagonal crack develops. As drift increases, the crack opens up and eventually loses its ability to transfer shear, subsequently losing vertical load bearing capacity. An example of such a failure mechanism is shown in Figure 1.



Figure 1: An example of what appears to be an unreinforced exterior joint failure.

Figure 2a shows the geometry of an exterior beam-column joint, where: L_c is the column length; L_b is the beam length; h_c is the column depth; h_b is the beam depth; and P is the column axial load. To formulate an expression for the plastic deformation capacity of an exterior beam-column joint, points of contraflexure will first be assumed to occur at the mid-height of columns and the mid-span of beams. It is then hypothesized that a diagonal crack in the beam-column joint forms at an angle α , given by Equation (4). Two assumptions are made: the elastic joint deformation before the diagonal crack develops is negligible; and all deformation is concentrated in a single joint shear crack after the diagonal crack is activated. In line with this, Figure 2b illustrates the rotation expected of the upper column due to joint crack opening and Figure 2c shows the displacement profile, where θ_{cr} is storey drift at which the joint shear crack develops, and θ_p is the plastic joint deformation capacity.

$$\alpha = \tan^{-1} \left(\frac{h_c}{h_b} \right) \quad (4)$$

The column rotation angle (β) is given as:

$$\beta = 2(\theta - \theta_{cr}) \quad (5)$$

where θ is the total storey drift.

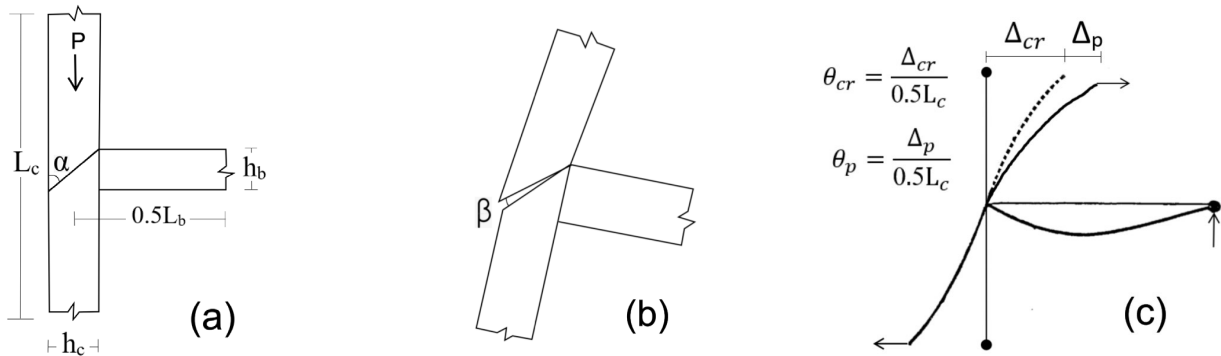

Figure 2: a) The geometry of an exterior joint, b) joint diagonal shear crack, and c) displacement profile.

The crack width (w) is a function of the distance to the rotation point (l_{cr}), as indicated in Figure 3 and Equation (6). However, it is limited to an effective crack width (w_{eff}). For a crack width larger than w_{eff} , the load transfer of shear and compression is assumed to be negligible.

$$w = \beta \cdot l_{cr} \quad (6)$$

where $0 \leq l_{cr} \leq L_{cr,eff}$

$$\text{and } L_{cr,eff} = \beta \cdot w_{eff} \leq \sqrt{h_c^2 + h_b^2}$$

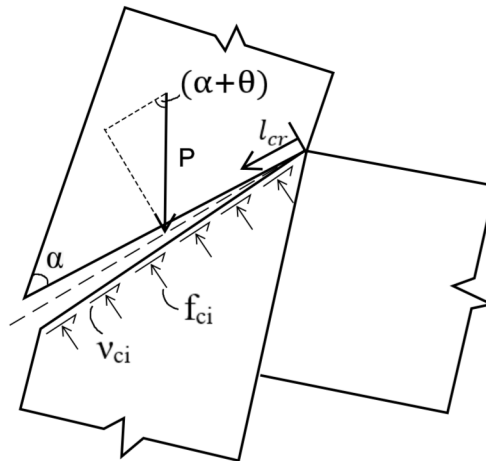

Figure 3: Illustration of forces and geometry of joint cracking.

As illustrated in Figure 3, the axial load is divided into two components that are parallel and perpendicular to the crack interface. They are resisted by the shear across the crack (v_{ci}) and the compressive stress (f_{ci}). The average compressive force is calculated as

$$f_{ci} = \frac{P \cdot \sin(\alpha + \theta)}{L_{cr,eff} b_j} \leq f'_{cc} \quad (7)$$

where f'_{cc} is the concrete crushing strength and b_j is the joint width. The joint width should take the greater of column width or beam width. The shear is expected to be provided primarily through aggregate interlock.

Vecchio and Collins (1986) developed a modified compression-field theory and derived the following expressions for v_{ci} :

$$v_{ci} = 0.18v_{ci,max} + 1.64f_{ci} - 0.82 \frac{f_{ci}^2}{v_{ci,max}} \quad (8)$$

$$v_{ci,max} = \sqrt{f'_c} \left(0.31 + \frac{24w}{a_g+16}\right)^{-1} \quad (9)$$

where a_g is the maximum aggregate size and f'_c is the concrete compression strength. The shear resistance over the crack interface contributed from aggregate interlock then becomes:

$$F_s = \int_0^{L_{cr,eff}} v_{ci} \cdot b_c \cdot dl_{cr} \\ = \frac{0.18 \sqrt{f'_c} b_c (a_g+16)}{24\beta} \cdot \ln \left(1 + \frac{24\beta L_{cr,eff}}{0.31(a_g+16)}\right) - \frac{0.82 f_{ci}^2 b_c}{\sqrt{f'_c}} \left(0.31 L_{cr,eff} + \frac{12\beta L_{cr,eff}^2}{a_g+16}\right) + 1.64 f_{ci} b_c L_{cr,eff} \quad (10)$$

In addition to aggregate interlock, dowel action of longitudinal reinforcement in column also provides shear resistance. The concrete cover in older RC columns is generally not significantly greater than the bar diameter and therefore, concrete splitting is likely to be the governing failure mode in dowel action. Jelić et al. (1999) have summarised a few empirical expressions that can estimate dowel force with concrete splitting failure. Based on equilibrium considerations, the structure becomes unstable (i.e. sliding of upper column) when the overall shear resistance is less than the demand $P \cdot \cos(\alpha+\theta)$ or when the concrete is crushed.

3 COMPARISON OF PREDICTIONS WITH EXPERIMENTAL DATA

Over the past two decades a number of valuable experimental tests on unreinforced exterior beam-column joint with plain bars have been conducted. Among these tests, the specimens with deformation concentrated in a single crack are used in this study to assess the proposed capacity estimation method. The test results and publications are provided in Figure 4. . The failure mechanisms of these specimens were either joint shear failure or beam yielding followed by joint shear failure; hence the lateral strength is governed by joint shear strength. The specimens were subjected to cyclic loads with axial load ratios under 25%. The reported damage states for these specimens are all similar; firstly inclined cracks are observed in the joint panel at a drift θ_{cr} . Then the lateral strength continues to increase with more severe diagonal cracks being developed, which could be explained by hardening behaviour. Once the peak strength (joint shear strength) is reached, rapid strength degradation usually occurs. The joint plastic deformation capacity (θ_p) is defined in this work as the difference between the drift at peak strength (θ_{peak}) and the drift at 20% strength reduction (θ_{NC}). One may argue that the joint's plastic deformation should start at θ_{cr} . However, the strength is still increasing between θ_{cr} and θ_{peak} , which means beam and column rotations are also contributing to this deformation. Including this part of the drift may lead to an unconservative estimation of joint plastic deformation capacity.

The joint plastic drift values from the experimental results, NZSEE guidelines, and proposed method are compared in Figure 4. Porter et al. (2007) developed various damage analysis methods that estimate the probability of exceeding a certain limit state. Of these, Method A deals with the situation where specimens reached failure, which is defined as the near collapse (NC) state in this case. The analysis uses fragility functions that require engineering demand parameters (e.g. θ_p) as input. The fragility function is idealised by a lognormal distribution with a median (x_m) and a lognormal standard deviation (β , also known as dispersion). Using this method, the median plastic drift is found to be $x_m = 1.3\%$, and the dispersion is $\beta = 0.8$. To test the normality of the samples, Porter et al. (2007) suggest using the Lilliefors goodness-of-fit test. As a result, the lognormal distribution of experimental data passes the test at the 5% significance level. The fitted fragility curve is plotted in Figure 5.

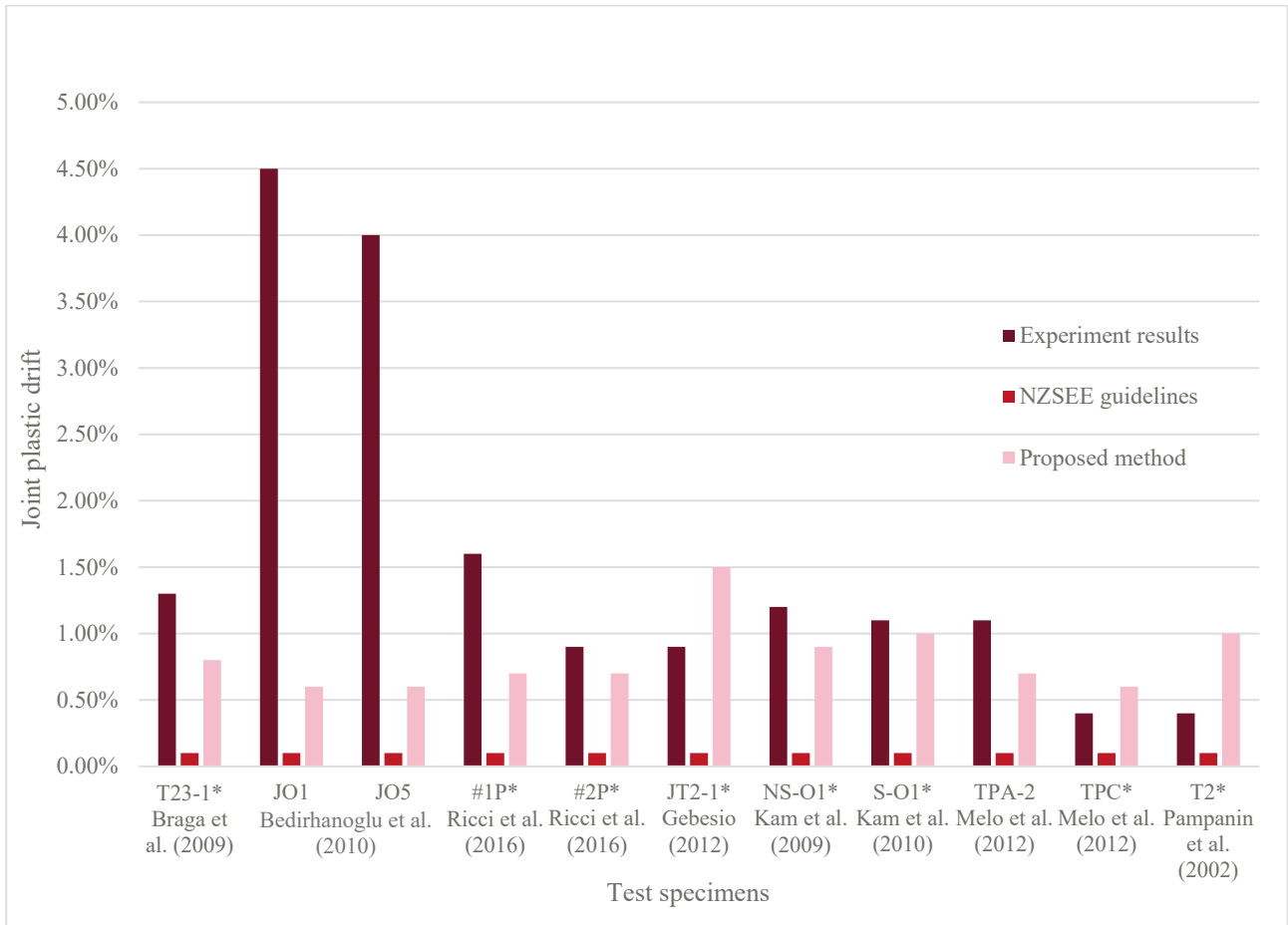

Note: * represents hooked longitudinal reinforcement anchorage, other specimens have longitudinal reinforcement bent into (90°) the joint core.

Figure 4: Comparing the experimental joint plastic drift with that predicted from NZSEE guidelines and proposed method.

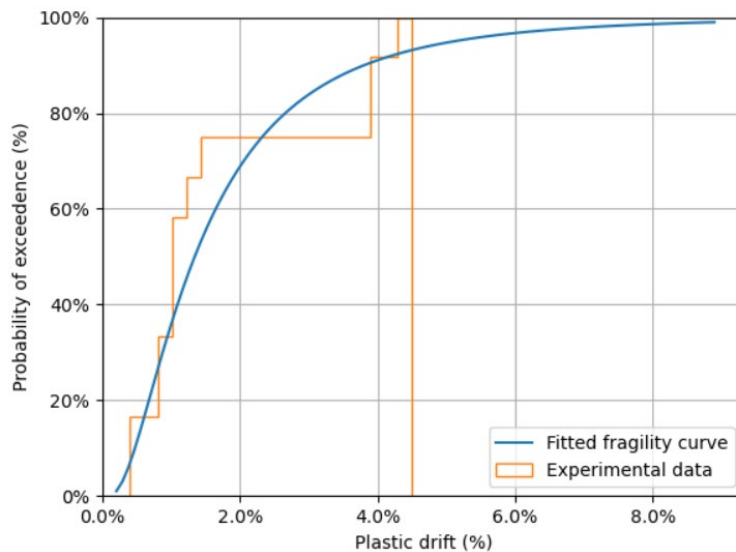

Figure 5: Fragility curve of joint test results.

4 DISCUSSION

A high dispersion in experimental data is observed and was somewhat expected for two main reasons. Firstly, the randomness in material characteristics means that even testing two identical specimens with the same loading protocols, the outcomes will be different. Secondly, there are significant uncertainties in analysis method and a number of simplifying assumptions have been made. Joint plastic deformation can be affected by many factors such as joint dimensions, axial load ratio, longitudinal reinforcement, concrete strength and test setup. Due to the relatively limited amount of test data, these factors are not treated separately and instead, an overall dispersion is used.

Comparing the plastic drift capacity observed in the tests with that predicted, the proposed mechanism generally provides a conservative underestimate of the capacity. However, the proposed approach is less conservative than the value of 0.001 provided in previous guidelines. The large variation in the predictions is attributed to the uncertainties in maximum aggregate size (a_g) and the limiting effective crack width (w_{eff}). By trialling a range of effective crack widths from 1 mm to 4 mm it is found that when the crack increases to a certain width, the plastic drift capacity approaches a plateau.

Worth noting that among the joint tests conducted in the literature, the specimens with hooked bar anchorage all developed a single diagonal shear crack in the joint panel where deformation is concentrated. There is a tendency for such anchorage configuration to develop an x-shaped shear crack (so called “concrete wedge” in Pampanin et al., 2002). Therefore, the proposed joint mechanism may be more suitable for estimating the plastic drift of joints with hooked bar anchorage. Finally, it is noted that all of the experimental testing was conducted using quasi-static testing and so there may be some doubt as to whether the observed drift capacities may be affected by the seismic acceleration of the structural members themselves (either side of the joint shear crack) and future research could consider this further.

5 CONCLUSIONS

A number of older RC frame buildings possess beam-column joints without transverse reinforcement and with plain longitudinal reinforcing bars. The guidelines recommended a value of 0.001 for exterior joint shear deformation at the ULS but by examining experimental test results from the literature, this research has found the value of 0.001 to be overly conservative. Therefore, a simple mechanics-based approach has been proposed to estimate the plastic drift capacity of the joint and frame. This approach assumes that post-cracking, deformation is concentrated in a single shear crack in the joint panel. The predictions suggest that post-cracking, an exterior joint can deform up to 1% without losing its gravity load carrying capacity. The quality of the prediction method is gauged by comparing predictions with the results of experimental tests reported in the literature. A median plastic drift capacity of 1.3% (with a dispersion of 0.8) is obtained from the experimental data assuming that a 20% strength reduction represents the ultimate deformation capacity. Compared to the experimental results, the proposed mechanism is found to be conservative generally. In conclusion, this paper has described a promising new method for the prediction of the plastic drift capacity of beam column joints without transverse reinforcement and possessing smooth round longitudinal bars. Further research should be carried out to improve the accuracy of the method and reduce the uncertainty in drift capacity estimates.

6 ACKNOWLEDGEMENTS

This research was partly supported by the Resilience to Nature’s Challenges National Science Challenge.

REFERENCE

- Bedirhanoglu, I., Ilki, A., Pujol, S., & Kumbasar, N. 2010. Behavior of deficient joints with plain bars and low-strength concrete. *ACI Journal*, 107-S29.
- Braga, F., Gigliotti, R., & Laterza, M. 2009. RC existing structures with smooth reinforcing bars: experimental behaviour of beam-column joints subject to cyclic lateral loads. *The Open Construction & Building Technology Journal*, 2009, 3, 52-67.
- Fenwick, R., & MacRae, G. 2009. Comparison of New Zealand standards used for seismic design of concrete buildings. *Bulletin of the New Zealand Society for Earthquake Engineering*, 42(3), 187-203.
- Genesio, G. 2012. Seismic assessment of RC exterior beam-column joints and retrofit with haunches using post-installed anchors. Doctoral thesis. University of Stuttgart, Germany.
- Kam, W.Y., & Pampanin, S. 2009. Experimental and Numerical Validation of Selective Weakening Retrofit for Existing Non-Ductile R.C. Frames. *ATC-SEI Conference on Improving the Seismic Performance of Existing Buildings and Other Structures*, Dec 2009. San Francisco, CA, USA.
- Kam, W.Y., Pampanin, S., & Bull, D. 2010. A summary of test results for selective weakening and post-tensioning for retrofit of non-ductile R.C. exterior beam-column joints. *2010 NZSEE Conference*, Wellington.
- Melo, J., Varum, H., Rossetto, T., & Costa, A. 2012. Cyclic response of RC beam-column joints reinforced with plain bars: An experimental testing campaign. *World Conference on Earthquake Engineering 15th WCEE*, Lisbon.
- MBIE/NZSEE. 2017. Part C2: assessment procedures and analysis techniques. *The Seismic Assessment of Existing Buildings*. NZSEE, Wellington.
- MBIE/NZSEE. 2018. Part C5: concrete buildings. *The Seismic Assessment of Existing Buildings*. NZSEE, Wellington.
- Pampanin, S., Calvi, G.M., & Moratti, M. 2002. Seismic behaviour of R.C. beam-column joints designed for gravity loads. *12th European Conference on Earthquake Engineering*. Sep 2002. London
- Pampanin, S., Magenes, G., & Carr, A. 2003. Modelling of shear hinge mechanism in poorly detailed RC beam-column joints. *2003 Symposium Concrete Structures in Seismic Regions*. Paper n.171. Athens, Greece.
- Porter, K., Kennedy, R., & Bachman, R. 2007. Creating fragility functions for performance-based earthquake engineering. *Earthquake Spectra*, Volume 23, No.2 471-489.
- Priestley M.J.N. 1998. Brief comments on elastic flexibility of reinforced concrete frames and significance to seismic design. *Bulletin of the New Zealand Society for Earthquake Engineering*, 31(4): 246-259.
- Ricci, P., De Risi, M. T., Verderame, G. M., & Manfredi, G. 2016. Experimental tests of unreinforced exterior beam-column joints with plain bars” *Engineering Structures*, 118 (2016), 178-194.
- Shafaei, J., Hosseini, A., Marefat, M.S., Ingham, J.M., & Zare H. 2017. Experimental Evaluation of Seismically and Non-Seismically Detailed External RC Beam-Column Joints. *Journal of Earthquake Engineering*, 21:5, 776-807
- Sullivan, T. J. 2019. *Draft Guidelines for simplified lateral mechanism analysis (SLaMA) of existing buildings*. SESOC/NZSEE, New Zealand.
- Vecchio, F. J. 1986. The modified compression-field theory for reinforced concrete elements subjected to shear. *ACI Journal*, 83(2), 219-231.