Modelling the out-of-plane buckling behaviour of BRBFs

S. Sistla, R. Chandramohan & T.J. Sullivan

University of Canterbury, Christchurch, New Zealand

ABSTRACT

The objective of this study is to assess the impact of modelling the out-of-plane buckling behaviour of buckling-restrained braced frames (BRBFs) on their estimated seismic performance. Several recent studies have highlighted the possibility of gusset plates and brace end-zones buckling out-of-plane before the buckling-restrained braces (BRBs) themselves yield. Very few of these studies have attempted to characterise the importance of capturing this failure mode in nonlinear models of BRBFs used to estimate their global seismic performance. The NZS 1170.5 requirements and NHERP design guidelines for BRBFs were used to design and analyse a BRBF building in this study. According to the results of the pushover analyses, the gusset plates appear to be undersized when designed according to the New Zealand building standards. Furthermore, the conventional BRBF modelling approach, which is incapable of simulating the out-of-plane buckling failure mode, overestimates the BRBF's base shear and deformation capacities by 2% and 550%, respectively. To improve the performance of the BRBF, the gusset plates were redesigned following suggestions adopted from the literature. Pushover analysis conducted on the revised BRBF models indicate enhanced BRBF performance and no out-of-plane buckling of the gusset plates.

1 INTRODUCTION

Prior to the Canterbury earthquake sequence, there existed only one BRBF building in New Zealand, which is the psychology building at the University of Canterbury. Nevertheless, BRBFs constitute nearly 50% of the new steel buildings erected during the Canterbury rebuild, replacing eccentric braced frames (MacRae and Clifton 2017). Despite the fact that BRBFs have become more popular since the Canterbury earthquakes, formal criteria for their design do not yet exist because the structural system is still relatively new in New Zealand. Furthermore, recent research has highlighted the possibility of brace end-zones and gusset plates buckling out-of-plane before the BRB core yields, and this failure mode is not explicitly accounted for in current design practice (MacRae et al. 2021, Yu et al. 2011, Tsai and Hsiao 2008, Westeneng et al. 2015, Zaboli et al. 2017, Vazquez et al. 2021). Although a number of experimental and analytical studies at the element and subassembly levels have been conducted to investigate the out-of-plane buckling failure mode of gusset plates and brace end-zones, comparatively few studies have related this failure mode to the overall performance of BRBF structures.

This study summarises the development of a numerical model of a BRBF building, capable of accurately capturing the out-of-plane buckling behaviour of its braces with bolted end connections. The development of this model represents the first step of a larger study aimed at benchmarking the seismic performance of BRBF buildings in New Zealand. A BRBF was initially designed in compliance with existing design practices in New Zealand. A realistic 3D planar model of the frame was developed in OpenSees (Mazzoni et al. 2006) and nonlinear static pushover analyses were conducted to study its behaviour under seismic loads. The significance of modelling the out-of-plane buckling failure mechanism is demonstrated by comparing the simulated response of the 3D model to that of a 2D model developed using conventional modelling techniques, incapable of capturing this failure mode.

2 BRBF BUILDING DESIGN

As a part of this study, a four-storey BRBF building (illustrated in Figure 1a) was designed for a site in Christchurch by modifying the design of a building originally developed by Yeow et al (2018). The building has four BRBFs along its perimeter, as shown in Figure 1b. It has a rectangular floor plan with dimensions 24 m × 40 m. The first storey is 4.5 m tall, and all subsequent storeys are 3.6 m tall. The bays along both the X and Y directions are 8 m wide. The equivalent static method and accidental eccentricity requirements from NZS 1170.5 were used to determine the lateral force distribution on the BRBFs. The seismic demand on the BRBFs in the X direction is slightly larger than in the Y direction due to the incorporation of accidental eccentricity requirements. It was assumed that both BRBFs in each direction share the seismic demand equally, and hence, the subsequent sections of this paper will discuss only one BRBF in the X direction.

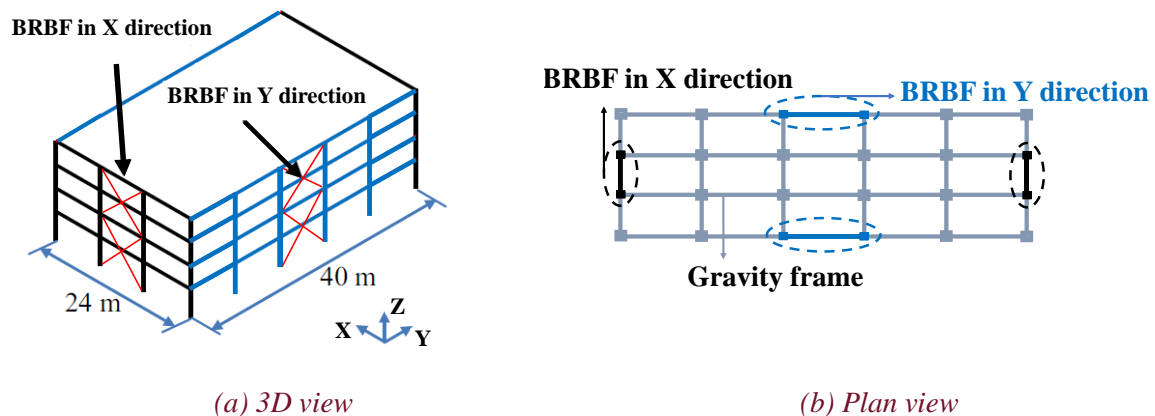

Figure 1: Schematic of the designed BRBF building (Yeow et al. 2018)

The frame and brace elements of the BRBF were sized using the capacity design approach (Equations 1-7). The braces in each storey were assumed to support 95% of the total storey shear. The storey shear supported by each individual brace (V_{br}) was thus computed by dividing 95% of the total storey shear (V_{st}) by the number of braces in a storey.

$$V_{br} = 0.95 \frac{V_{st}}{4} \quad (1)$$

The required cross-sectional area of each brace (A_{br}) was then computed as follows:

$$P_{br} = \frac{V_{br}}{\cos(\theta)} \quad (2)$$

$$A_{br} = \frac{F_{ybr}}{0.9P_{br}} \quad (3)$$

where P_{br} is the axial force in the brace, θ is the angle of inclination of the brace, and F_{ybr} is the yield strength of the brace. The compressive strength of a BRB generally dictates its design since Poisson's effect and friction between the BRB core and casing result in a marginally higher overstrength in compression than in tension. The compressive strength of the BRB core (P_{brc}) is computed as

$$P_{brc} = F_{ybr} A_{pr} R_y \omega \beta \quad (4)$$

where A_{pr} is the provided cross-sectional area of the brace, R_y is the yield stress overstrength factor, β is the tensile overstrength factor, and ω is the ratio of compressive to tensile overstrength. The axial compressive forces in the columns ($P_{col_seismic}$) were estimated using Equation 5 and cumulatively summed up over successive storeys.

$$P_{col_seismic} = P_{brc} \sin(\theta) \quad (5)$$

The total gravity load on a storey was assumed to be shared by the gravity frame and the BRBF, in proportion to their respective tributary areas. The axial compressive forces in the columns due to the gravity loads ($P_{col_gravity}$) were cumulatively summed up in a similar manner as the seismic loads. The total axial loads to be resisted by columns (P_{col_total}) and beams (P_{beam}) were then computed using Equations 6 and 7 respectively.

$$P_{col_total} = P_{col_seismic} + P_{col_gravity} \quad (6)$$

$$P_{beam} = P_{brc} \cos(\theta) \quad (7)$$

According to the current design practice in New Zealand, the gusset plates are designed to resist buckling using the column curve of NZS 3404, by modelling them as equivalent column using an effective length factor (k) of 0.7. The width (b_w) and length (L_e) of the equivalent struts are estimated using the Thornton's method, as shown in Figure 2.

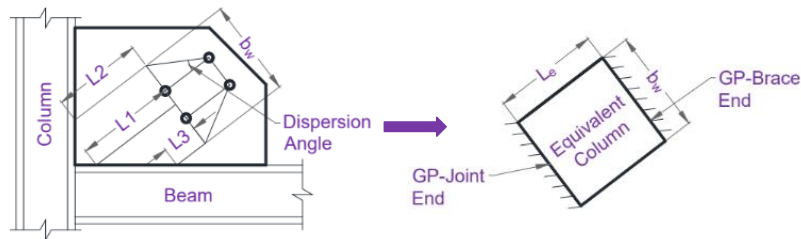

Figure 2: Equivalent column approximation according to Thornton's method (Vazquez et al. 2018)

Table 1 summarises the final member sizes obtained by following the design method outlined above. As demonstrated in Figure 3a, BRBs have non-uniform cross-sections with a yielding core and elastic end-zones. The braces were treated as members with uniform cross-sections to simplify the numerical model for elastic analysis, as illustrated in Figure 3b. The equivalent brace has the same cross-sectional area as the yielding core but a different Young's modulus (E_{wp}), which is calculated as:

$$E_{wp} = E_s \frac{L_{wp}}{L_{core} + 2 L_{end} \frac{A_{core}}{A_{end}}} \quad (8)$$

where L_{end} is the length of the end-zone, L_{yc} is the length of the yielding core, K_{end} is the axial stiffness of the end-zone, E_s is the Young's modulus of steel, and K_{yc} is the axial stiffness of the yielding core.

A linear elastic analysis was conducted by applying the gravity loads and the lateral loads estimated from the equivalent static method to a linear elastic model developed in OpenSees. Since all the members satisfied the code-based design checks, no changes to the member sizes were required.

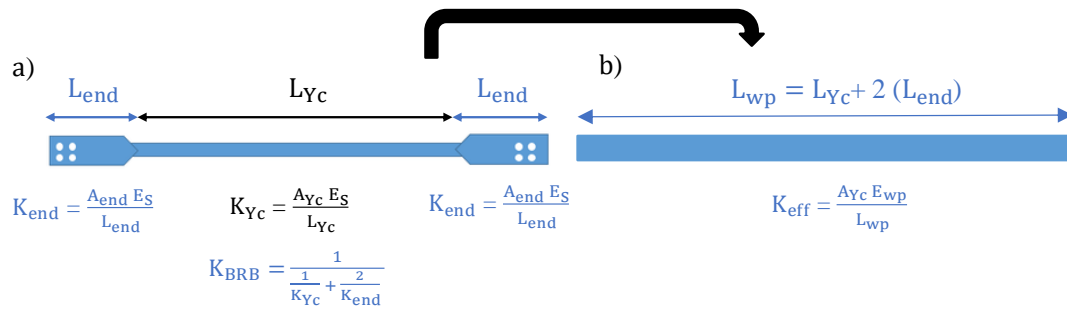

Figure 3: Simplified BRB model for linear elastic analysis

Table 1: Summary of member details

Section	Member	Floor
350 WC 230	Column	1, and 2
350 WC 197	Column	3, and 4
530 UB 92.4	Beam	1, and 2
530 UB 92.4	Beam	3, and 4
Rectangular section – 105 mm × 30 mm	Brace	1, and 2
Rectangular section – 87 mm × 20 mm	Brace	3, and 4
Rectangular section – 455 mm × 16 mm	Gusset plate	1, and 2
Rectangular section – 370 mm × 14 mm	Gusset plate	3, and 4

3 NONLINEAR BRBF MODELS

Two 3D nonlinear planar models representing one of the two identical BRBFs in the X direction were developed in OpenSees, and their schematic is illustrated in Figure 4. The occurrence of an asymmetric brace buckling mode was ensured in the first model (model OOP-A) by modelling gusset plate geometric imperfection in opposite directions at either end of each brace, whereas the development of a symmetric buckling mode was encouraged in the second model (model OOP-S) by modelling the imperfections in the same direction. Figure 5 illustrates these two out-of-plane buckling modes. Displacement-based fibre elements were used to model the BRB cores, end-zones, and gusset plates. The BRB core and restrainer assemblies were modelled using hollow circular cross sections, with a diameter and thickness large enough to represent the flexural stiffness of the BRB restrainer while retaining the actual axial stiffness of the core. The Steel02 material model with isotropic hardening was used to represent the hysteretic behaviour of the brace core and the model parameters were adopted from a previous study conducted by Victorsson (2011). The gusset plates were modelled as elements with equivalent uniform cross-sections (illustrated in Figure 2), connected to the beam-column joints using rigid offsets, as shown in Figure 4. The brace end-zones and gusset plates were modelled using the Steel02 material model as well. In order to capture the out-of-plane buckling failure mode, i) an initial out-of-plane geometric imperfection of $L_{Gp}/100$ (Zaboli et al. 2017) was introduced at the interface of the gusset plates and the brace end zones (where L_{Gp} denotes the length of the gusset plate); and ii) an

imperfection of $2 \times 1 \text{ mm} = 2 \text{ mm}$ was provided at the interface of the brace end-zone and the BRB core, assuming a clearance of 1 mm between the core and the restrainer.

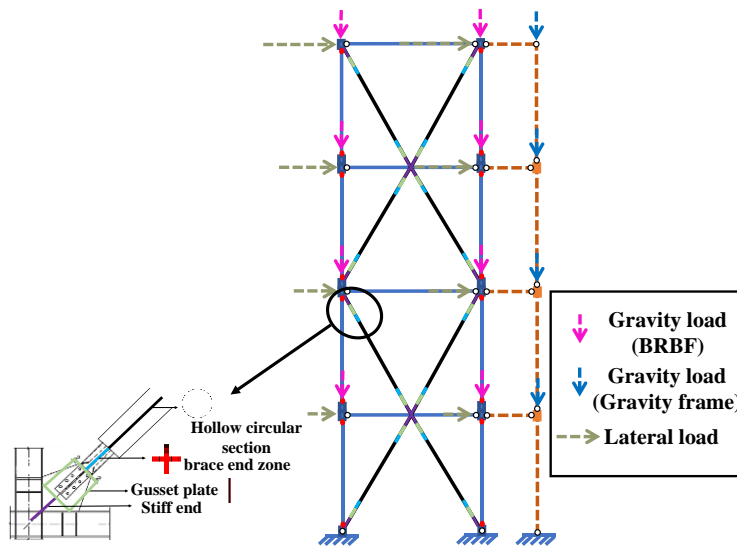

Figure 4: 3D planar BRBF model

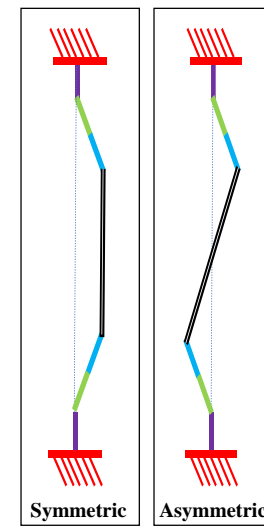

Figure 5: BRB out-of-plane buckling modes

Elastic beam-column elements with concentrated plastic hinges at both ends were used to represent the columns. The Ibarra-Medina-Krawinkler (IMK) model (Ibarra et al. 2005) was used to represent the hysteretic behaviour of the plastic hinges and its parameters were computed using the equations proposed by Lignos (2008). The beams were modelled as elastic beam-column elements with pinned connections to the beam-column joints. The beam-column joints themselves were restrained from translating out-of-plane using single-point constraints. P- Δ effects were captured by applying gravity loads on a pin-connected leaning column, as shown in Figure 4. An eigenvalue analysis determined the frame's fundamental modal period to be 0.97 s.

In order to conduct a controlled study of the influence of out-of-plane buckling on the global response of the BRBF, an analogous 2D model (model OOP-N) of the frame was also developed in OpenSees. This 2D model, incapable of capturing the out-of-plane buckling failure mode, is a representative of the modelling approach commonly employed to simulate the behaviour of BRBFs in research and practice.

Table 2: Summary of BRBF models developed in OpenSees

Model	Dimensions	Out-of-plane imperfections	Elements used for GPs	Elements used for brace end-zones
model OOP-A	3D	asymmetric	DBFE**	DBFE**
model OOP-S	3D	symmetric	DBFE**	DBFE**
model OOP-N	2D	NC*	DBFE**	DBFE**

NC* - not considered in the model, DBFE** - displacement-based fibre elements

4 NONLINEAR STATIC PUSHOVER ANALYSIS

Nonlinear static pushover analyses with a loading profile proportional to the first mode shape, were conducted to examine the performance of the 3D models with asymmetric (model OOP-A) and symmetric (model OOP-S) imperfections. Failure of the frame during pushover analysis is defined as the point at which a 20% reduction in the peak base shear is recorded. The pushover curves of both models are illustrated in Figure 6. Studies like Takeuchi et al. (2014) and Zaboli et al. (2017) have indicated the increased likelihood of observing an asymmetric buckling mode over a symmetric buckling mode due to the lower energy requirement of the former. The peak base shear of model OOP-A was found to be 2000 kN, while that of model OOP-S was found to be 2040 kN, supporting the suggestions of previous studies that the asymmetric buckling mode is a lower energy mode. Out-of-plane buckling failure occurred in models OOP-S and OOP-A at roof drifts of 2.1% and 1%, respectively.

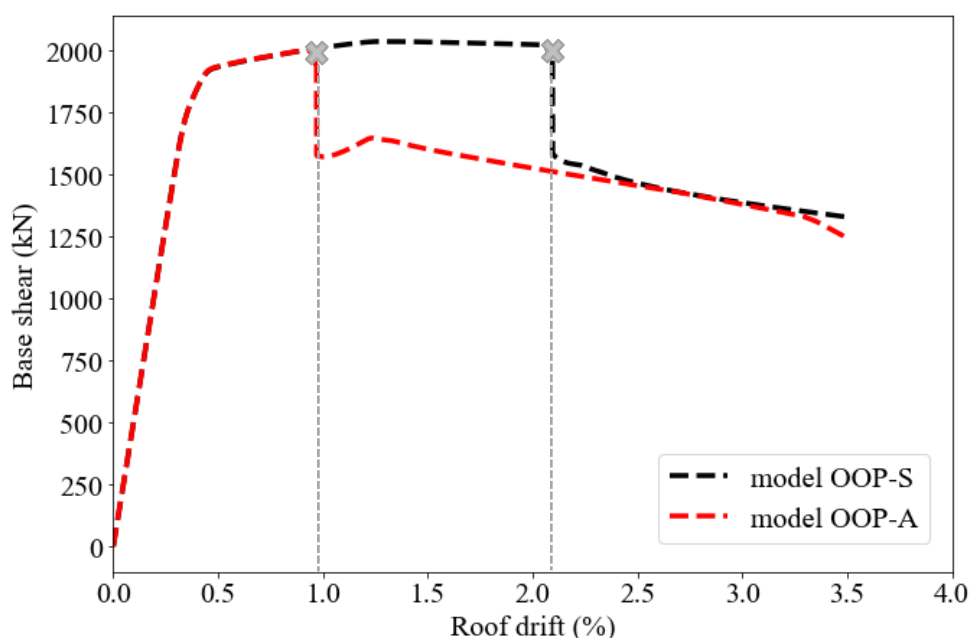

Figure 6: Performance comparison of BRBFs with symmetrical (OOP-S) and asymmetrical buckling modes (OOP-A)

In both models, out-of-plane buckling of the gusset plates was observed only in the first storey, and the point at which buckling occurs is highlighted on their respective pushover curves. Few of the compression braces in model OOP-A could not achieve their design axial capacities due to the out-of-plane buckling failure of the gusset plates. Based on the previously defined failure criteria, the drift capacity of the model OOP-S was nearly 50% greater than that of the model OOP-A.

A pushover analysis was also conducted on model OOP-N to assess the significance of explicitly modelling the out-of-plane buckling of the brace end-zones and gusset plates. The pushover over curves of models OOP-A, and OOP-N are depicted in Figure 7. Since the out-of-plane failure mechanism was not included in model OOP-N, all the braces were able to achieve their design axial capacities and plastic hinges were developed at the base of the first storey columns at 3.2% roof drift. The collapse mechanisms developed by the two models were also observed to be significantly different as seen in Figure 7. The results indicate that the conventional numerical modelling approach that ignores out-of-plane buckling can overestimate the base shear and deformation capacities by 2% and 550%, respectively.

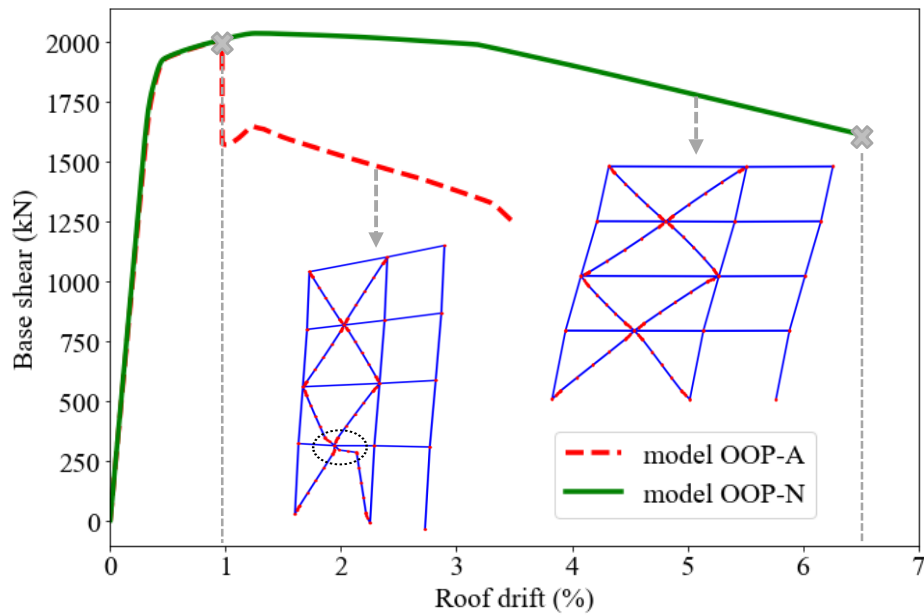

Figure 7: Performance comparison of the conventional model (OOP-N) and BRBF with asymmetrical buckling mode (OOP-A)

Tsai et al. (2008), Chou et al. (2012), and Vazquez et al. (2018) observed that when gusset plates were designed with an effective length factor (k) of 2.2, their estimated buckling capacity was comparable to the experimental results. As a result, the gusset plates were redesigned with $k=2.2$. Pushover analyses were conducted on models OOP-A and OOP-S with revised gusset plate dimensions, and the results are shown in Fig. 8. The pushover curves of model OOP-A_ $k=2.2$, model OOP-S_ $k=2.2$, model OOP-N_ $k=0.7$, and model OOP-N_ $k=2.2$ are identical because the revised thickness of the gusset plates was sufficient to prevent the out-of-plane buckling failure. Figure 8 further demonstrates that there is no difference in the performance of BRBF models developed using the conventional approach regardless of the gusset plate design in this case. Table 3 summarises the pushover analysis results for all models.

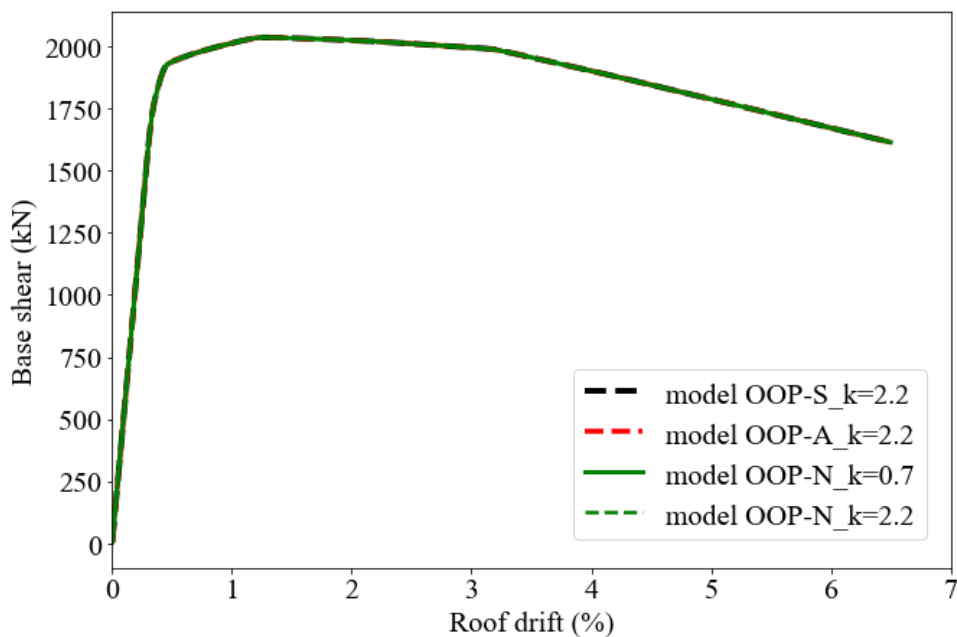

Figure 8: Pushover curves of the BRBF models with revised gusset plate design

Table 3: Summary of pushover analyses results

Model	Gusset plate effective length factor (k)	Peak base shear (V_p) (kN)	Roof drift at $0.8 V_p$ (%)
model OOP-A	0.7	2000	1.00
	2.2	2040	6.50
model OOP-S	0.7	2040	2.10
	2.2	2040	6.50
model OOP-N	0.7	2040	6.50
	2.2	2040	6.50

5 CONCLUSION

A BRBF building was designed as per the current practice in New Zealand and modelled using a novel approach capable of capturing its out-of-plane buckling behaviour. Nonlinear static pushover analysis of the models OOP-A and OOP-S showed significant loss of strength due to out-of-plane buckling of the gusset plates at roof drifts of 1% and 2.1%, respectively. Few of the compression braces in model OOP-A could not achieve their design axial capacities due to the out-of-plane buckling failure of the gusset plates. The peak base shear of the model OOP-A was 2% lower than the peak base shear of the model OOP-S, showing that the asymmetric brace buckling mode is more likely to be observed than the symmetric buckling mode. The conventional BRBF modelling approach, which is incapable of simulating the out-of-plane failure mode behaviour, overestimated the BRBF's deformation capacity by 550%, respectively.

Upon redesigning the gusset plates with a k value of 2.2 instead of 0.7, as per the recommendations of some recent studies, no out-of-plane buckling was observed. As a result, there was no difference in the performance of BRBF models OOP-A and OOP-N. The out-of-plane buckling failure mode was observed to control the response of the BRBF designed in this study following conventional design practice in New Zealand. Nevertheless, further studies examining different brace and building configurations are needed before any generalisations can be made.

6 ACKNOWLEDGEMENT

The authors express their sincere gratitude to Gregory MacRae for his suggestions. This project was supported by the Built Environment Theme of the Resilience to Nature's Challenges 2.

7 REFERENCES

- Chou, C.C. and Liu, J.H., 2012. Frame and brace action forces on steel corner gusset plate connections in buckling-restrained braced frames. *Earthquake Spectra*, 28(2), pp.531-551.
- Dimitrios, L., 2008. Sidesway collapse of deteriorating structural systems under seismic excitations. *PhD thesis. Stanford University*.
- Ibarra, L.F., Medina, R.A. and Krawinkler, H., 2005. Hysteretic models that incorporate strength and stiffness deterioration. *Earthquake engineering & structural dynamics*, 34(12), pp.1489-1511.

- MacRae, G.A., Clifton, G.C. and Bruneau, M., 2018. New Zealand research applications of, and developments in, low damage technology for steel structures. In *Key Engineering Materials* (Vol. 763, pp. 3-10). Trans Tech Publications Ltd.
- MacRae, G., Lee, C.L., Vazquez-Colunga, S., Cui, J., Alizadeh, S. and Jia, L.J., 2021. BRB system stability considering frame out-of-plane loading and deformation zone. *Bulletin of the New Zealand Society for Earthquake Engineering*, 54(1), pp.31-39.
- Mazzoni, S., McKenna, F., Scott, M.H. and Fenves, G.L., 2006. The open system for earthquake engineering simulation (OpenSEES) user command-language manual.
- Takeuchi, T., Ozaki, H., Matsui, R. and Sutcu, F., 2014. Out-of-plane stability of buckling-restrained braces including moment transfer capacity. *Earthquake engineering & structural dynamics*, 43(6), pp.851-869.
- Thornton, W.A., 1984. Bracing connections for heavy construction. *Engineering Journal*, 21(3), pp.139-148.
- Tsai, K.C. and Hsiao, P.C., 2008. Pseudo-dynamic test of a full-scale CFT/BRB frame—Part II: Seismic performance of buckling-restrained braces and connections. *Earthquake Engineering & Structural Dynamics*, 37(7), pp.1099-1115.
- Vazquez-Colunga, S.Y., Lee, C.L. and MacRae, G.A., 2018. Effects of out-of-plane displacements on load capacity of gusset plates in buckling restrained braced frames. In *Key Engineering Materials* (Vol. 763, pp. 892-899). Trans Tech Publications Ltd.
- Vazquez-Colunga, S.Y., Lee, C.L. and MacRae, G.A., 2021. Bidirectional loading performance of gusset plates in buckling restrained braced frames. *Engineering Structures*, 242, p.112521.
- Victorsson, V. K., 2011. The reliability of capacity-designed components in seismic resistant systems. *PhD thesis. Stanford University*.
- Westeneng, N., Lee, C.L. and MacRae, G.A., 2015, September. Early failure of gusset plates in buckling restrained brace frames. In *Steel Innovations 2015 Conference, Auckland* (pp. 3-4).
- Yeow, T.Z., Orumiyehi, A., Sullivan, T.J., MacRae, G.A., Clifton, G.C. and Elwood, K.J., 2018. Seismic performance of steel friction connections considering direct-repair costs. *Bulletin of Earthquake Engineering*, 16(12), pp.5963-5993.
- Yu, Y.J., Tsai, K.C., Li, C.H., Weng, Y.T. and Tsai, C.Y., 2011. Analytical simulations for shaking table tests of a full scale buckling restrained braced frame. *Procedia engineering*, 14, pp.2941-2948.
- Zaboli, B., Clifton, G.C. and Cowie, K., 2017. Out-of-plane stability of gusset plates using a simplified notional load yield line method. In *New Zealand Society for Earthquake Engineering (NZSEE) Annual Technical Conference*.